

SC型

CMC STANDARD SPLIT MUFF COUPLING

一般機械装置用

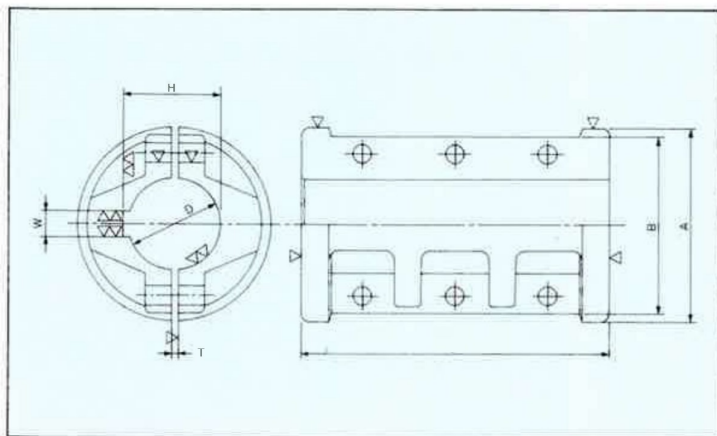

当SC型には、キー溝により各々N(新JIS)とF(旧JIS)の2種類があります。
ご注文の際に、ご指定ください。

例 SC-50N
SC-100F



SC型 仕様

型番	D _{He}	キ ー 溝				A	B	L	T	ボルト	重量 Kg	伝達トルク Kgf·m
		N(新JIS)		F(旧JIS)								
		W _{JIS9}	H	W _{F7}	H							
SC-25N.F	25	8	28.3	7	28	56	50	90	1.6	4-M6	0.8	15.7
SC-30N.F	30	8	33.3	7	33	67	60	106	1.6	4-M6	1.5	22.2
SC-35N.F	35	10	38.3	10	38.5	78	70	125	1.6	4-M8	2.5	35
SC-40N.F	40	12	43.3	10	43.5	90	80	140	1.6	6-M8	3.9	44.8
SC-50N.F	50	14	53.8	12	53.5	112	100	180	2.0	6-M10	7	72
SC-60N.F	60	18	64.4	15	65	132	120	212	2.0	6-M10	11	127
SC-65N.F	65	18	69.4	18	71	145	130	224	2.5	6-M12	13	174
SC-70N.F	70	20	74.9	18	76	155	140	250	2.5	6-M12	18	210
SC-75N.F	75	20	79.9	20	81	165	150	265	2.5	6-M12	21	258
SC-80N.F	80	22	85.4	20	86	180	160	280	2.5	6-M14	27	291
SC-85N.F	85	22	90.4	24	93	190	170	300	2.5	6-M14	30	408
SC-90N.F	90	25	95.4	24	98	200	180	315	3.0	6-M16	37	453
SC-95N.F	95	25	100.4	24	103	212	190	335	3.0	6-M16	42	510
SC-100N.F	100	28	106.4	28	109	224	200	355	3.0	6-M18	50	639
SC-110N.F	110	28	116.4	28	119	256	230	400	3.0	8-M18	85	920
SC-120N.F	120	32	127.4	32	130	256	230	400	3.0	8-M18	85	920
SC-125N	125	32	132.4	32	135	290	260	450	3.0	8-M20	120	1280
SC-130N	130	32	137.4	35	141	290	260	450	3.0	8-M20	120	1280
SC-140N	140	36	148.4	35	151	315	290	500	3.0	8-M22	160	1740
SC-150N	150	36	158.4	38	162	315	290	500	3.0	8-M22	160	1740

※ SC-80以上の型番製品は全て受注生産品となります。